

TRACK: The Nitro Pit, AZ
EVENT: Nitro Challenge / Finished 2nd A-Main
DRIVER: Gerardo Gonzalez **DATE:** 2-20-10

PROTRAC™ SUSPENSION KIT FOR SLASH®

FRONT SUSPENSION

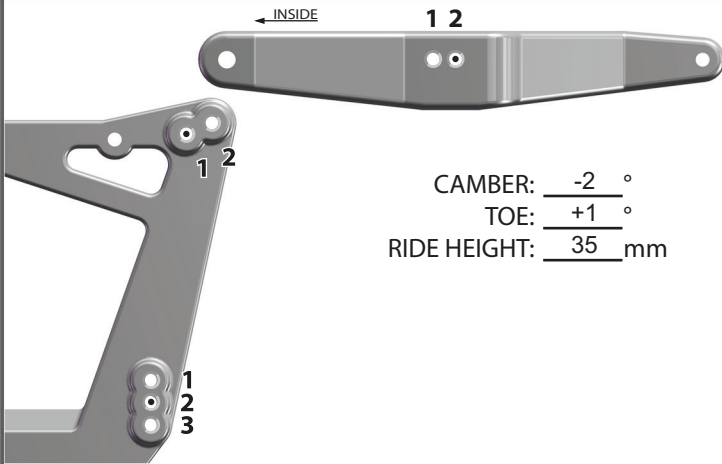

CAMBER: -2 °
 TOE: +1 °
 RIDE HEIGHT: 35 mm

REAR SUSPENSION

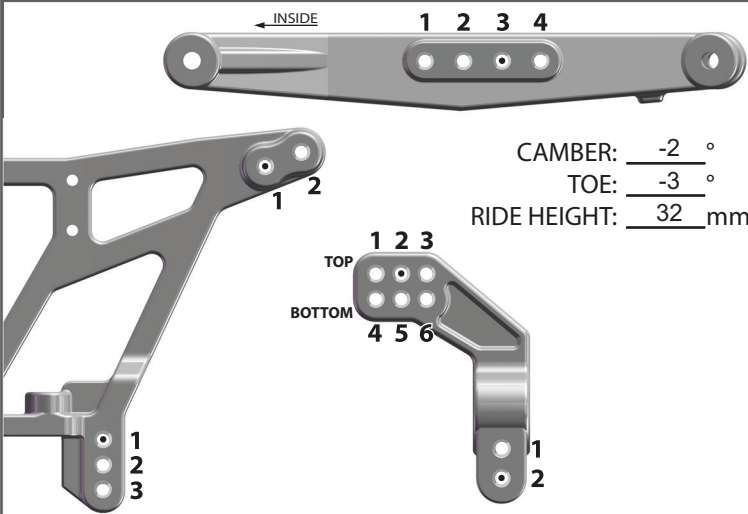

CAMBER: -2 °
 TOE: -3 °
 RIDE HEIGHT: 32 mm

ELECTRONICS

MOTOR: Novak Havok System 8.5
 PINION: 18T BATTERY: Reedy 5000 LiPo
 SPUR GEAR: Stock 86T PLACEMENT: Rear

TRACK INFORMATION

TRACTION: HIGH MED LOW
 SURFACE: SMOOTH BUMPY BLUE GROOVE
 CONDITIONS: SOFT DIRT CLAY WET DUSTY
 OTHER: _____

FRONT TIRES

TIRE: Caliber SC
 COMPOUND: M2
 INSERT: Closed Cell
 WHEEL: ProTrac™ Split Six

REAR TIRES

TIRE: Caliber SC
 COMPOUND: M3
 INSERT: Closed Cell
 WHEEL: ProTrac™ Split Six

POWERSTROKE FRONT SHOCKS

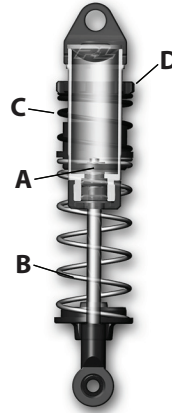

(A) PISTON: STOCK
 OIL WEIGHT: 40
 (B) PRIMARY SPRING: STOCK
 (C) SECONDARY SPRING: STOCK
 DROOP SPACER: N/A mm
 COMPRESSION SPACER: N/A mm
 (D) SPRING ADJUSTMENT: 0 mm

STOCK SHOCKS

(A) PISTON: _____
 OIL WEIGHT: _____
 SPRING: _____
 DROOP SPACER: _____ mm
 COMPRESSION SPACER: _____ mm
 (D) SPRING ADJUSTMENT: _____ mm

POWERSTROKE REAR SHOCKS

(A) PISTON: STOCK
 OIL WEIGHT: 35
 (B) PRIMARY SPRING: STOCK
 (C) SECONDARY SPRING: STOCK
 DROOP SPACER: N/A mm
 COMPRESSION SPACER: N/A mm
 (D) SPRING ADJUSTMENT: 3 mm

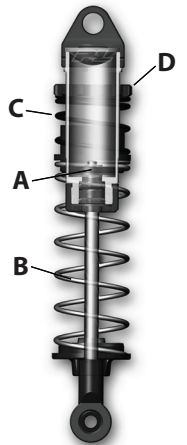

STOCK SHOCKS

(A) PISTON: _____
 OIL WEIGHT: _____
 SPRING: _____
 DROOP SPACER: _____ mm
 COMPRESSION SPACER: _____ mm
 (D) SPRING ADJUSTMENT: _____ mm

LINK SETTINGS

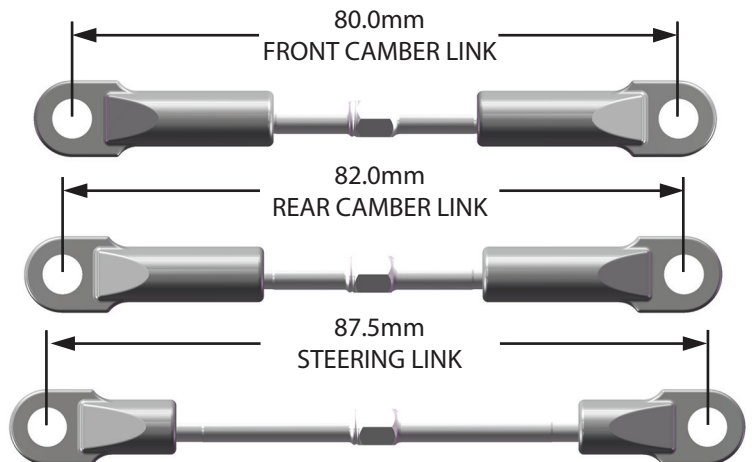

RESET FORM v.1

For complete step-by-step instructions
 visit PROLINERACING.com

